



## YBCO Synthesis and Characterization (Electrical Transport Option)

<http://education.qdusa.com/experiments.html>

Prof. Stephen Tsui  
California State University San Marcos

*In this Educational Module, students will attempt to synthesize and electrically characterize their own polycrystalline samples of  $\text{YBa}_2\text{Cu}_3\text{O}_{7-\delta}$  (YBCO) superconductor, the first material discovered with a superconducting critical temperature ( $T_c$ ) above liquid nitrogen's boiling temperature.*

### **Introduction:**

Superconductivity is an exciting phenomenon whereby certain materials at low temperatures demonstrate zero electrical resistance and the expulsion of magnetic field, also known as the Meissner effect [1]. This phenomenon occurs due to the Cooper pairing of electrons in the material that are able to conduct without scattering. In this experimental activity, you will synthesize and electrically characterize your own polycrystalline samples of  $\text{YBa}_2\text{Cu}_3\text{O}_{7-\delta}$  (YBCO) superconductor, which if properly synthesized possesses a superconducting critical temperature ( $T_c$ ) above liquid nitrogen's boiling temperature (77 K) [2]. The observation of such a "high  $T_c$ " was exciting because previous superconductors required liquid helium cooling, which was relatively impractical and cost prohibitive. The pursuit of high temperature superconductivity in this era created such a fervor that the 1987 American Physical Society March Meeting will forever be remembered as the "Woodstock of Physics," where on March 18, two thousand physicists and chemists crammed themselves into the New York Hilton ballroom and overflow rooms to listen to talks and hold discussions from 7:30 pm to 3:15 am [3].

### Student Learning Outcomes:

- Students will learn solid state reaction techniques and synthesize a polycrystalline ceramic sample of YBCO.
- Students will develop proficiency in sample preparation techniques that involve attaching small wire leads to samples using silver paint.
- Students will operate the Electrical Transport Option (ETO) of the VersaLab cryostat and gain experience in low temperature experiment.
- Students will apply foundational knowledge of relevant solid state physics to resistance vs. temperature characterization.

### Safety Information:

Before attempting to perform any parts of this student experiment, please read the entire contents of: this Educational Module, the VersaLab User's Manual (1300-001), and the Electro-Transport Option Manual (1084-700), and observe all instructions, warnings and cautions. These are provided to help you understand how to safely and properly use the equipment, perform the experiments and reach the best student learning outcomes.

Quantum Design Inc. disclaims any liability for damage to the system or injury resulting from misuse, improper operation of the system and the information contained in this Educational Module.

The following Safety warnings apply to this Educational Module. We recommend that you study them carefully and discuss the details with your instructor before starting the work:

**WARNING!**

Always use **Personal Protective Equipment (PPE)** during every step of sample preparation. Failure to do so might cause bodily harm.





### TOXIC HAZARD!

Acetone is toxic if swallowed. For more information consult the Material Safety Data Sheet available on this website:

<http://www.guidechem.com/msds/110-20-3.html>



### CRUSHING HAZARD!

Before using the die and hydraulic press, please read the entire contents of the User's Manual specific to that equipment, and observe all instructions, warnings and cautions. Failure to do so might cause bodily harm.



### HOT SURFACE!

Before using the furnace and combustion boats to sinter the samples, please read the entire contents of the User's Manual specific to that equipment, and observe all instructions, warnings and cautions. Failure to properly handle hot surfaces might cause bodily harm.



### FIRE HAZARD!

Before using the furnace to sinter the samples, please read the entire contents of the User's Manual specific to that equipment, and observe all instructions, warnings and cautions. Failure to do so might cause a fire hazard, bodily harm.

## Materials List

Synthesis	Sample Mounting	Measurement
Y <sub>2</sub> O <sub>3</sub> Powder	Zoom Stereo Microscope	Multimeter
BaCO <sub>3</sub> Powder	Calipers	VersaLab ETO
CuO Powder	25 μm diameter Pt Wire	
Mortar and Pestle	Lighter	
Balance	Scissors	
Weighing Paper or Weighing Boats	Leitsilber 200 Silver Paint	
Spatula or Scoopula	Tweezers	
Hydraulic Press	Thin stick or needle	
13 mm Press Die	Apiezon H Grease	

Tube Furnace		
Combustion Boat		

### YBCO Synthesis

- 1) The precursor compounds are  $Y_2O_3$ ,  $BaCO_3$ , and  $CuO$ . Determine the stoichiometric ratios necessary to yield 2 grams of  $YBa_2Cu_3O_7$ . Focus on the Y, Ba, and Cu ratios, since the heat treatment will remove the C and supply the oxygen content.
- 2) You will decide on how to process your materials in the tube furnace. Search the physics and chemistry literature in order to come up with a heat treatment recipe. Note that typical synthesis procedures require many hours in the furnace, such that it may take days to synthesize your sample.
- 3) Carefully weigh out the quantities required and place the compounds into a mortar bowl.
- 3) Grind the combined powder using the mortar and pestle, applying a circular motion as you grind.
- 4) Use a chemical spatula or scoopula to remove the compound from the mortar and into a crucible. Apply your heat treatment using the tube furnace. When heating the samples, it is suggested to provide oxygen flow via an air supply line. Many recipes call for multiple heating ramps with re-grinding in between treatments.
- 5) In order to create a ceramic pellet, extract the powder from the crucible and place it in a die for pressing. An application of 10,000 psi for one minute should be sufficient.

The material should be a deep black by the end of the process.



Figure 1. Completed YBCO pellet.

## Measurement Background

Nearly all fundamental materials characterization methods rely on the proper measurement of current and voltage. As such, experimental setups must be considered in terms of their equivalent electronic circuits in order to properly characterize a physical quantity. The heart of such a circuit is Ohm's law,  $V = IR$ , where  $V$  is the voltage drop across and  $I$  is the current through a resistance value  $R$ . From the resistance, one can obtain the material resistivity, which is the intrinsic character of a material to hinder electrical conduction. In a typical sample measurement, the resistivity is defined to be

$$\rho = \frac{RA}{L},$$

where  $R$ ,  $A$ , and  $L$  are the resistance, cross-sectional area, and length of the sample, respectively.

The sample puck of the VersaLab (Figure 3) clearly depicts three channels with gold-plated pads labeled  $I+$ ,  $V+$ ,  $V-$ , and  $I-$  for four-wire resistance measurement. It should be noted that the ETO does not support the use of Channel 3 (though other Quantum Design instruments do). Two-wire measurement is also available using  $I+$  and  $V-$ .

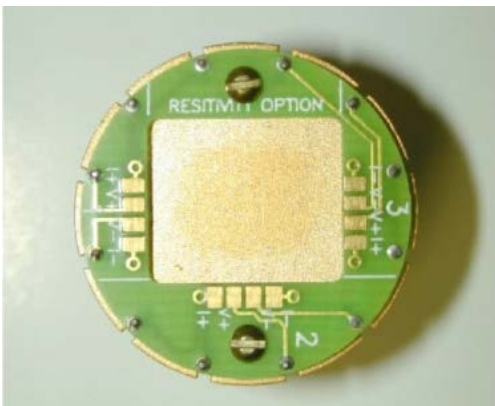

Figure 2. The VersaLab Puck. Notice the clearly labeled contact pads for the three measurement channels.

As a starting point, we consider the 2-leads measurement as illustrated below in Figure 3. In the 2-leads technique, current is applied to two electrodes attached to a load resistance. A voltmeter in parallel measures the entire voltage drop across the attached leads and the sample to be

measured. This form of measurement occurs, for example, whenever a hand-held multimeter is used. However, the drawback behind this technique is that the lead resistances of the measuring device contribute to the voltage reading, i.e. the contact resistance is indistinguishable from the load resistance. In typical characterization of materials, this method has very limited uses.

### Two-Wire Resistance Measurement

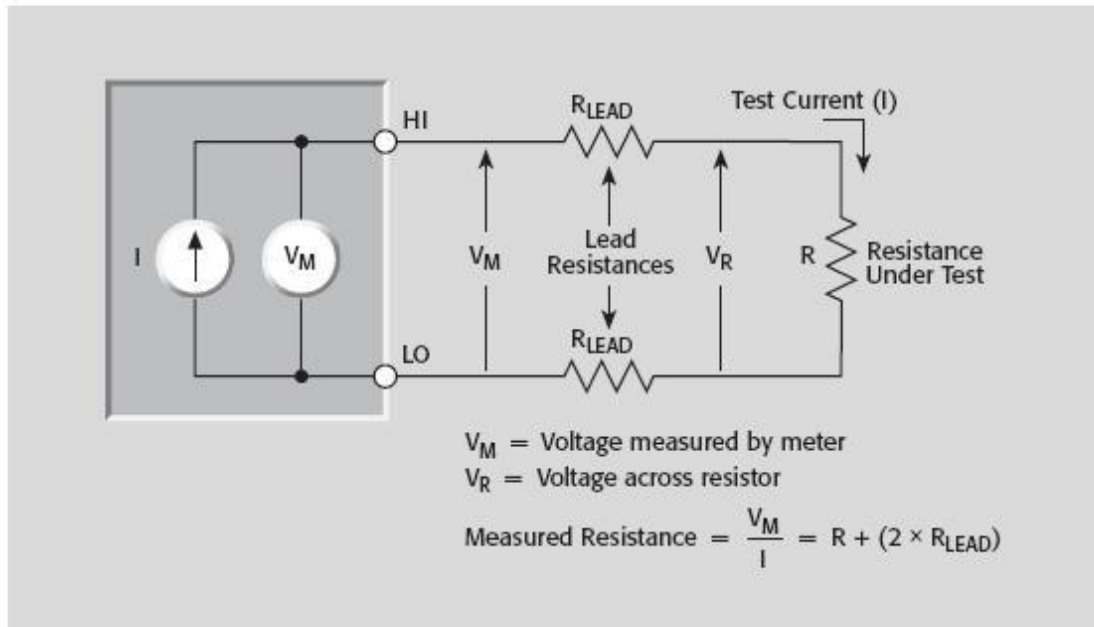

Figure 3. The circuit diagram for a typical 2-leads electronic configuration. Because the voltmeter is connected in parallel with the current source leads, the measured voltage drops occur over all leads and the sample, resulting in a total resistance measurement that encompasses every resistance in the circuit. [Adapted from 4]

The standard 4-leads technique illustrated in Figure 4 typically overcomes this drawback. The load resistance to be measured has four contacts attached. Measurement current is applied via the two outermost contacts whereas the two innermost contacts are connected to a voltmeter. In principle, the voltmeter input is at high impedance, thereby preventing the flow of measurement current in the innermost leads. As a result, the voltage drop that is recorded occurs between the two inner electrodes, eliminating any resistive contribution from the electrodes themselves. This is a very elegant technique from an electronics standpoint, but in reality, the voltage reading is heavily dependent upon the contact geometry and quality.

## Four-Wire Resistance Measurement

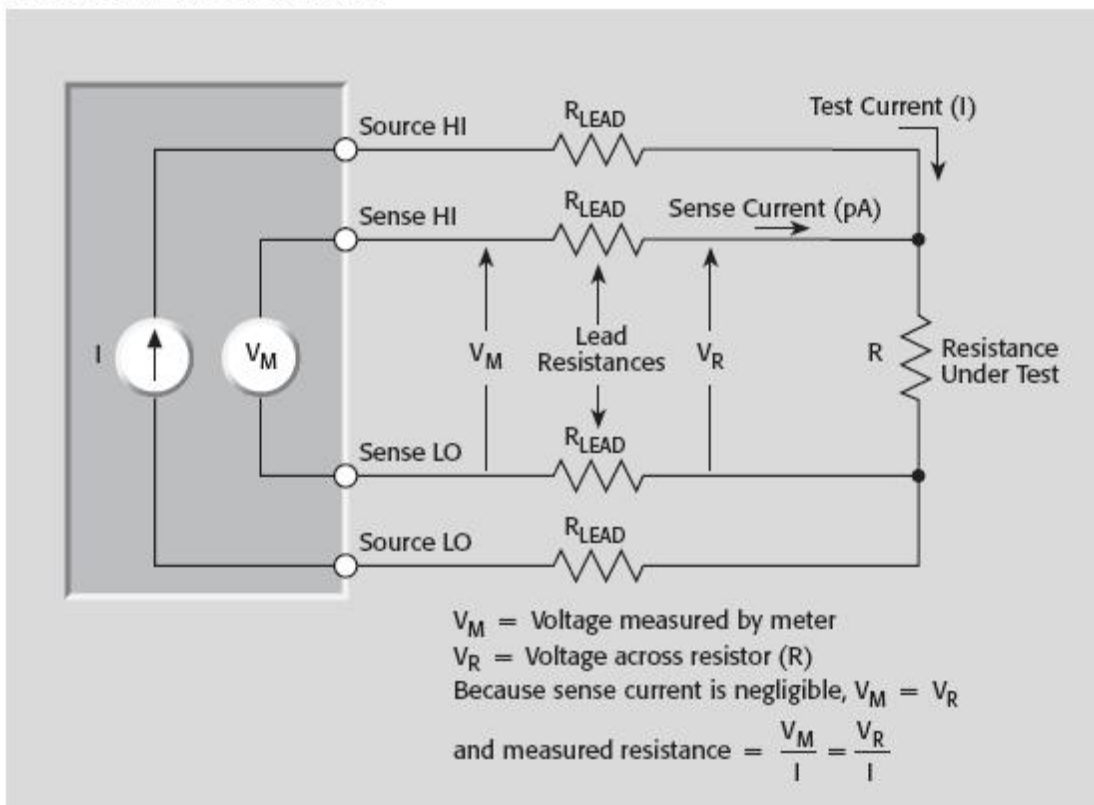

Figure 4. The circuit diagram for a typical 4-leads electronic configuration. Here, the voltmeter is attached to the sample via two leads separate from the current leads. Due to the negligible current in the voltmeter leads, the voltage drop, hence measured resistance, occurs only across the sample under test. [Adapted from 4]

## YBCO Sample Preparation and Mounting

1) Cut a piece of weigh paper or cigarette paper in order to cover the gold plated sample holder on the VersaLab puck. This will prevent the sample from shorting. Apply a thin layer of thermal grease to the gold area, lay the paper on top of it, and add another layer of grease over the paper. It is recommended to use Apiezon H grease.

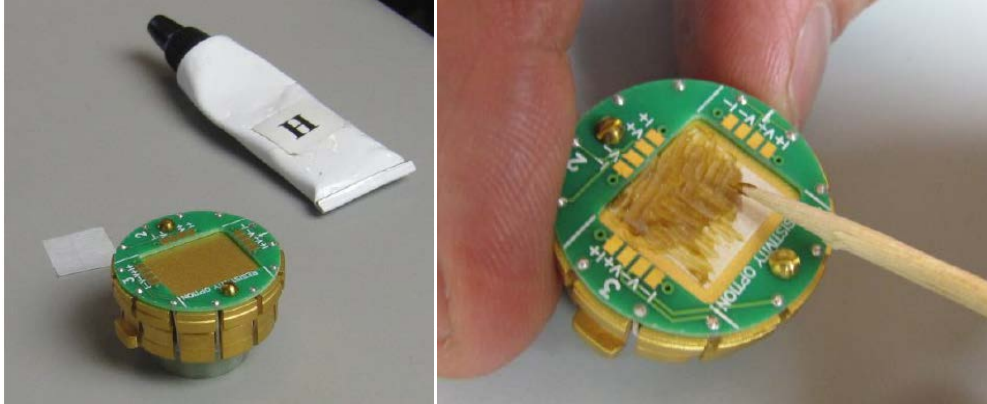

Figure 5. Apiezon H grease and paper application in order to prevent a short to the sample, keep the sample in place, and provide good thermal contact.

2) Measure the thickness of the pellet.



Figure 6. Thickness measurement of pellet in order to determine the cross-sectional area for the resistivity calculation.

3) The pellet should encompass the entire area of the sample puck. Choose whether you wish to connect the pellet to Channel 1 or Channel 2, as Channel 3 is not used with the ETO. You may opt to measure two samples at the same time, and that will require sawing or breaking pellets into smaller samples.



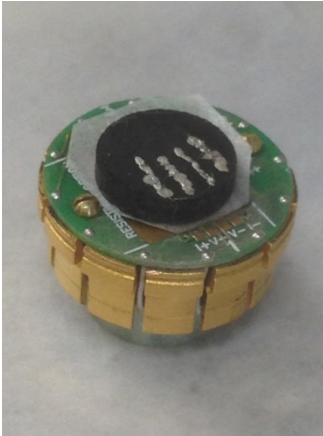

Figure 7. Sample mounted on the VersaLab puck with contacts already in place.

4) Obtain a strand of Pt wire and anneal it by running a lighter flame over it. This will soften the wire and make it easier to work with. Cut the wire with some spare length to connect the samples to the puck channel pads.

5) Using tweezers and a microscope, attach four Pt wires to your sample. The two inner wires will measure voltage while the two outer wires measure current. Silver paint will be used to attach the wires, so before getting started, it is useful to place a drop of silver paint on weighing paper or a glass slide and get a feel for how its viscosity changes as it dries. Use a thin stick or needle to play with this and see if you can control placing a small droplet of paint on a surface.

When you are ready to work with the sample, one method to attach leads is to lay individual wires in the locations that you want and placing a droplet of silver paint at the location with the small stick or needle. This is sufficient to measure the bulk properties of the sample, but painting stripes across the entire face of the pellet will allow for greater bulk measurement coverage.

Any mistakes can be remedied with a cotton tip soaked in ethanol or the creative use of a needle, stick, or razor blade when the silver paint has dried. In an extreme case, the surface layer of the pellet can be sanded off.

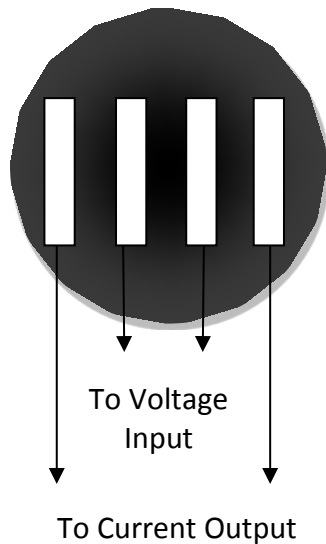

Figure 8. Four-lead measurement configuration for the sample pellet.

6) Measure the distance between the inner voltage contacts, which will give the length  $L$  in order to calculate the resistivity. Also measure the length of the voltage contacts in order to determine the cross sectional area in conjunction with the thickness measurement from Step 2.

7) Place the sample onto the VersaLab puck and use silver paint to connect the other ends of the wires to either Channel 1 or Channel 2. The I and V pads are clearly labeled.

8) There are several methods to check the quality of the contacts, but the most straightforward would be to insert the puck into the diagnostic puck box accessory for the VersaLab and measure the resistances between any two leads using a hand-held multimeter.



Figure 9. Testing connections on the VersaLab puck via the puck box.

### **Sample Measurement Using the ETO**

Refer to your VersaLab manual to prepare the cryostat for operation.

- 1) Place the puck in the insertion tool and lock it into place. Make sure that the puck is snug and does not rotate once locked.
- 2) Make sure that the VersaLab sample chamber is stable at 300 K with the magnet discharged. Use the VENT CONT command to vent the chamber, and then open the vacuum flange.
- 3) It is suggested to insert the puck with its keying notch aligned either to the right or left. When the tool has been inserted into the bottom, rotate the tool such that the notch will turn towards you. You should feel the puck drop slightly once the notch is properly aligned. Give the tool a gentle push downwards, release the lock, and lift out.
- 4) Replace the vacuum flange and activate the PURGE AND SEAL command. Once the chamber has been purged, use the ETO resistivity console to perform a quick 4 wire measurement of the sample or samples. If there is no reading, then a wire has broken in the process of mounting the puck.
- 5) Create a sequence to sweep temperature and measure 4-wire resistance. In order to save time, you may use large temperature intervals to measure from 300 K to 100 K and then use finer temperature intervals to measure from 100 K to 50 K in order to properly catch the superconducting transition (if your synthesis was successful!). You may

refer to ETO measurement parameter guidance for current, frequency, and autoranging in the transport newsletter:

[http://www.qdusa.com/sitedocs/newsletters/Applications\\_Newsletter\\_Fall\\_2013.pdf](http://www.qdusa.com/sitedocs/newsletters/Applications_Newsletter_Fall_2013.pdf)

6) Run the sequence, and display the measurement in real time. Once the data has been acquired, plot the resistivity vs. temperature using the dimensions of the sample and voltage lead placements that you previously measured.

### **Data and Discussion**

1) If you achieved superconductivity, what is your value of  $T_C$ ? Also, what was the temperature at which the onset of the transition occurred, and how broad was your transition in degrees K?

2) If your sample was not superconducting, did it demonstrate metallic or semiconducting behavior? How can this be concluded from the data, and what is the physical reasoning behind these particular resistance vs. temperature behaviors?

3) Compare your results with those of your peers. What was their  $T_C$ ? What was their room temperature resistivity? What synthesis methods yielded the best superconducting YBCO?

4) YBCO is a Type II superconductor. Perform some research and explain the difference between a Type I and Type II superconductor.

5) The Electronic Transport Option essentially employs a digital lock-in amplifier to perform the 4-wire measurement. Perform some research and explain the measurement principle of a lock-in amplifier.

### **References**

[1] For example, C. Kittel, *Introduction to Solid State Physics*, Wiley.

[2] M.K. Wu, J.R. Ashburn, C.J. Torng, P.H. Hor, R.L. Meng, L. Gao, Z.J. Huang, Y.Q. Wang, and C.W. Chu, "Superconductivity at 93 K in a new mixed-phase Y-Ba-Cu-O compound system at ambient pressure," *Physical Review Letters* **58**, 908-910 (1987).

[3] K. Chang, "Physicists remember when superconductors were hot," *The New York Times*, March 6, 2007.

<http://www.nytimes.com/2007/03/06/science/06supe.html? r=0>

[4] *Low Level Measurements Handbook*, 6<sup>th</sup>. Ed, Keithley.